

# 600W Bidirectional DC/DC Converter

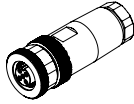

## User Manual

## In the box



M12 connector

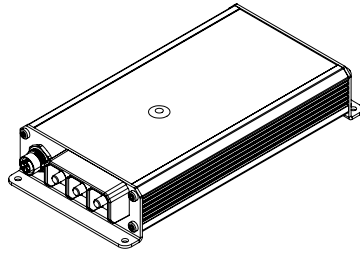

600W Bidirectional  
DC/DC Converter



3x M6 nuts



3x M6 split washer

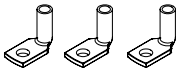

3x 16mm<sup>2</sup> cable lug



4x 16mm self tapping  
mounting screws



Manual

## Tools for installation

T20 Screwdriver

10mm socket wrench

10-120mm<sup>2</sup> crimp tool

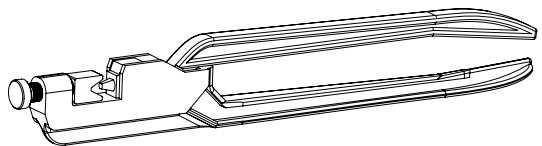

# Specification

Electrical Parameter	Value
Supply Voltage	10,9V - 32V
Input Current	0-45A
Output Voltage	14,4V or 28,8V
Output Current	0-40A
Output Control	5 stage charge
Wakeup Input Range	0-36V
Wakeup Input (Deactivate)	<3,0V
Wakeup Input (Activate - Delayed 15sec)	>4,0V
Power consumption (Idle):	<1,6 W
Power consumption (Sleep):	<1 mW
Operating temperature range:	-25 to 50 °C
Weight:	620 g
Dimensions:	222 x 110,5 x 40 mm

DC Input Operation Parameter	Value (12V)	Value (24V)
Under Voltage (1sec)	11,5V <sup>1</sup>	23,0V <sup>1</sup>
Under Voltage (30sec)	12,0V <sup>1</sup>	24,0V <sup>1</sup>
Under Voltage Recover	12,2V	25,6V
Over Voltage (1sec)	17,0V	34,0V
Over Voltage (30sec)	16,0V	32,0V
Over Voltage Recover	15,0V	32,0V

<sup>1</sup> - Voltages are compensated by current coming into the DC-DC Converter with a predefined impedance of 15mΩ. (ex: 40A \* 15mΩ = 600mV Compensation)

Input	Value		Output	Value
12V	0-45A	↔	12V	0-40A
12V	0-45A		24V	0-20A
24V	0-20A		12V	0-40A
24V	0-20A		24V	0-20A

## Standards and approvals

Low Voltage Directive 2014/35/EU  
EN62368-1:2014

EMC 2014/30/EU  
EN61000-6-2:2005, EN61000-6-3:2007 / A1:2011  
EN50498:2010 (UNECE Regulation 10)  
E13 10R-05 14880 (E-mark)

RoHs Directive 2011/55/EU  
EN50581:2012

## LED Codes

The LED indications all have same individual behaviour:

LED	Behavior	Indication	
Power	Green	Solid	Active - wakeup signal active
	Green	1 Flash	Standby - wakeup signal active
Charge IN or OUT	Green	Solid	Charging has finished - battery full
	Green	Flash 1Hz	Constant voltage - (Lead: >80%) - (Lithium: >95%)
	Green	Flash 4Hz	Constant current - (Lead: <80%) - (Lithium: <95%)
Charge IN & OUT	Red	1 Flash	Short circuit - restart to recover
	Red	2 Flash	Temperature too high - revocers automatically
	Red	3 Flash	All Other failures
Jumpstart	Green	Solid	Jumpstart in final minut - Start the vehicle.
	Green	Flash 4 Hz	Jumpstart in progress - do not start the vehicle yet
	Red	Flash	Jumpstart not able to run.
Data	Green	Solid	CAN active - device controlled
	Green	Flash 1Hz	CAN active - unknown device
IN/OUT 12V	Green	Solid	12V functionality active
IN/OUT 24V	Green	Solid	24V functionality active
IN/OUT 12V & 24V	Green	Solid	Automatically selection is in process
IN/OUT 12V / 24V	Red	Flashing	Voltage is out of range.

## Charge Algorithm

The Charge algorithm is a 5-stage charge cycle with level 1 charging the battery with high current allowing active loads to be in parallel.

Level 2 is performing the absorption charging at lower current avoiding gas voltage.

The Level 2 state is time limited avoiding infinite charging if loads absorb the charge energy.

After the battery is fully charged float charge will keep the battery full even if loads are active. Charging will restart if loads absorb more than allowed during float.

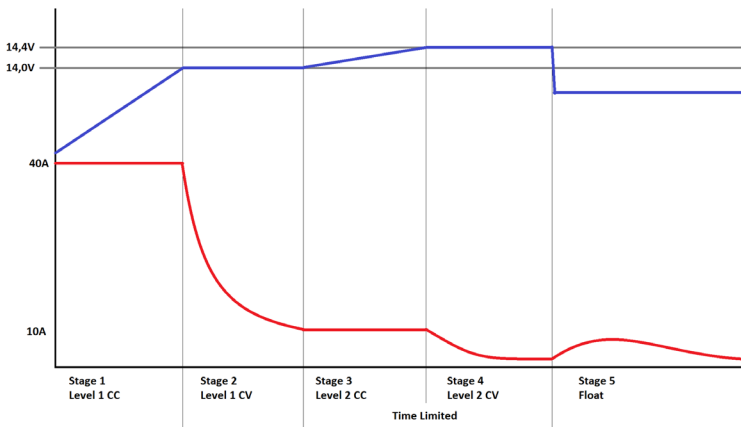

Stage	Description	Value (12V)	Value (24V)
Stage 1	Level 1 Constant current	40A	20A
Stage 2	Level 2 Constant voltage	14,0V	28,0V
Stage 3	Level 1 Constant current1	10A	10A
Stage 4	Level 2 Constant voltage1	14,4V	28,8V
Stage 5	Float charge2	13,5V	27,0V

1 - Level 2 stage is time limited to 8h and hereafter the battery is considered full.

2 - If the current overpass 10A during float charge charging is restarted at stage 1.

# Installation of an extra lead auxiliary battery

## Lead Starter Battery to Lead Aux Battery

DC-DC Converter in a system with Lead Acid start battery and lead acid Auxiliary battery.

The converter can operate with either a 12V or 24V input battery and a 12V or 24V output battery.

The converter will during start up automatically detect if one or the other configuration has been selected and all four configurations are possible.

### Step 1 - DC Cables

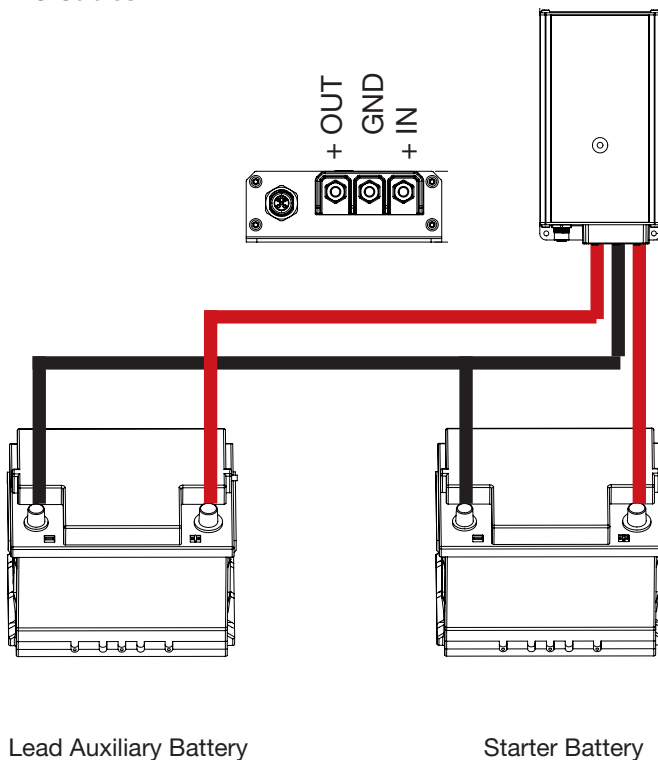

Secure the power cable lug to the terminal studs, first with the spring washer, then with the nut.

Apply between 5.5 Nm (49 lb-in.) and 6 Nm (53 lb-in.) of torque to each nut. Do not overtighten the nut.

**CAUTION:** The maximum torque rating of the terminal studs on the DC-DC Converter is 6.5 Nm (58 lb-in). The terminal studs may be damaged if excessive torque is applied.

## Step 2 - DATA Connection

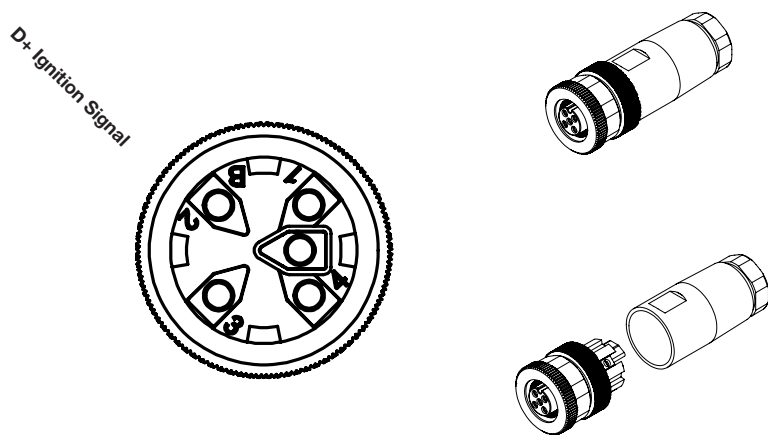

For automatic charging when the engine turns on.

Connect a 0,75 mm<sup>2</sup> wire to PIN 2 in the M12 connector

- 1 Single Wire
- 2 D+ Ignition Signal**
- 3 GND
- 4 CAN High
- 5 CAN Low

## **Jump start**

The DC/DC Converter can provide reverse charge current into the starter battery giving start aid option. The DC/DC Converter will reverse charge into the starter battery for 5 min. then the user should be able to start the vehicle.

### **To activate jump start**

Turn Car Key on.

Push 3 sec on the SETUP button on the DC/DC Converter.

This will activate reverse charging for 5 min. Reverse charging can be terminated at any time by pushing the select button again.



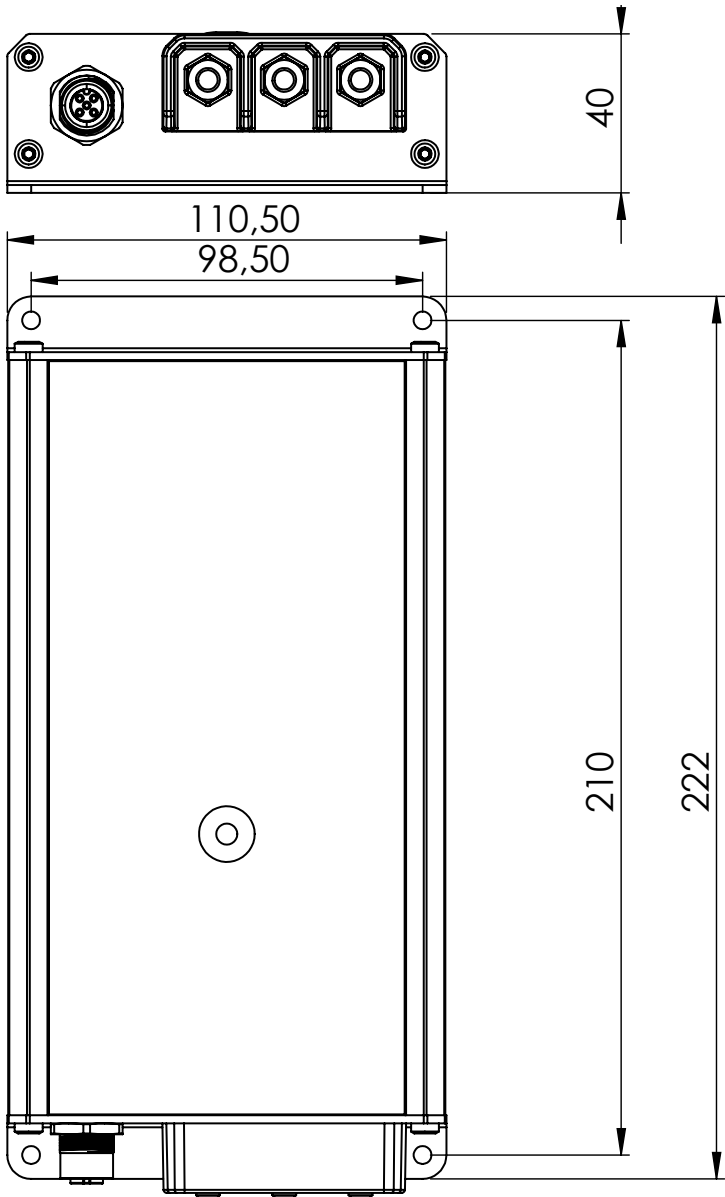

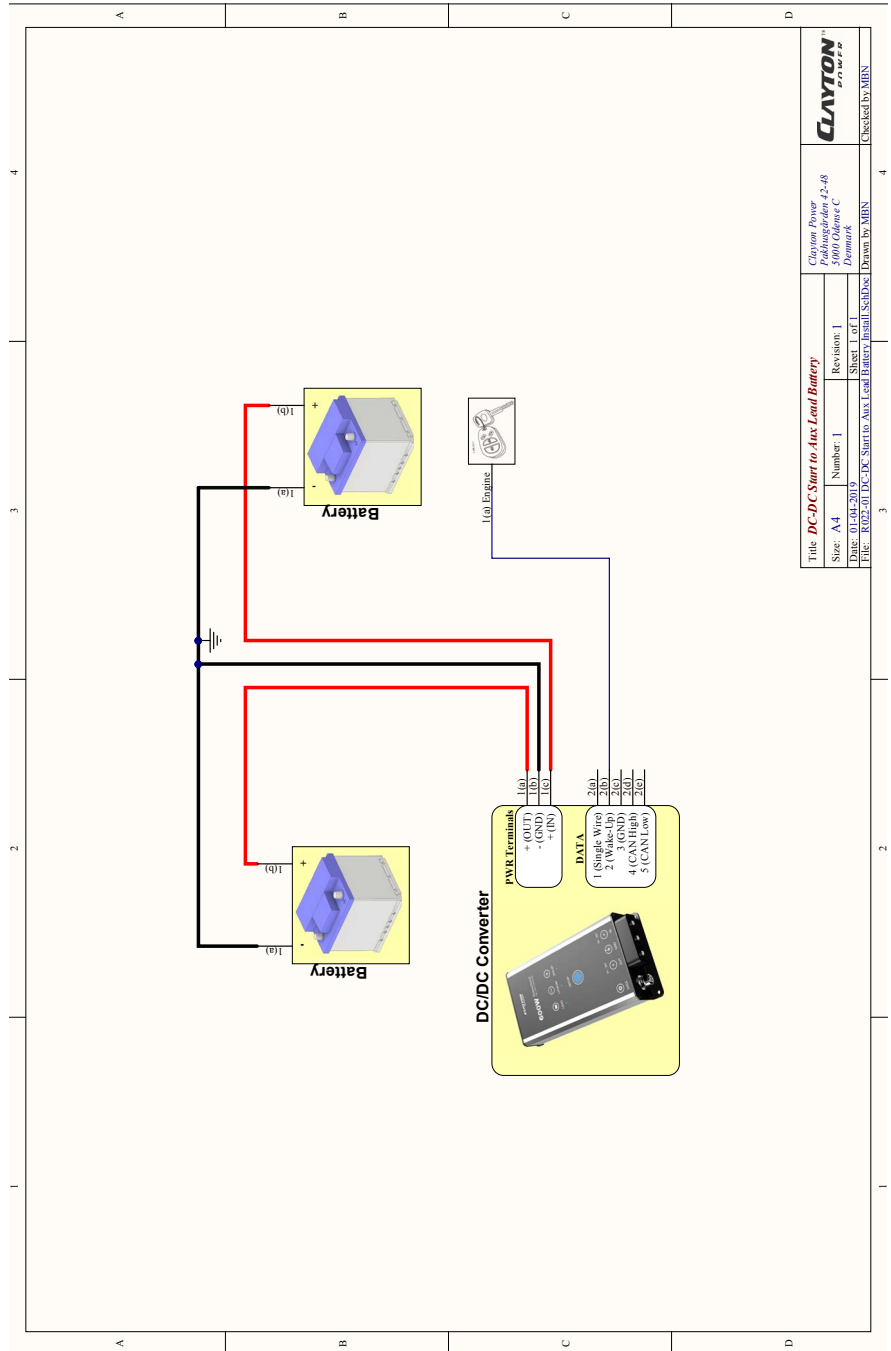

Title <b>DC-DC Start to Aux Lead Battery</b>		Clayton Power Produktionslinien 42-48 2000 Oelence C Zemmerlin	
Size: A4	Number: 1	Revision: 1	
Date: 01.04.2019		Sheet: 1 of 1	
File: R02-01 DC-DC Start to Aux Lead Battery install (S) (S) (S)		Drawn by: MBN	

Checked by: MBN

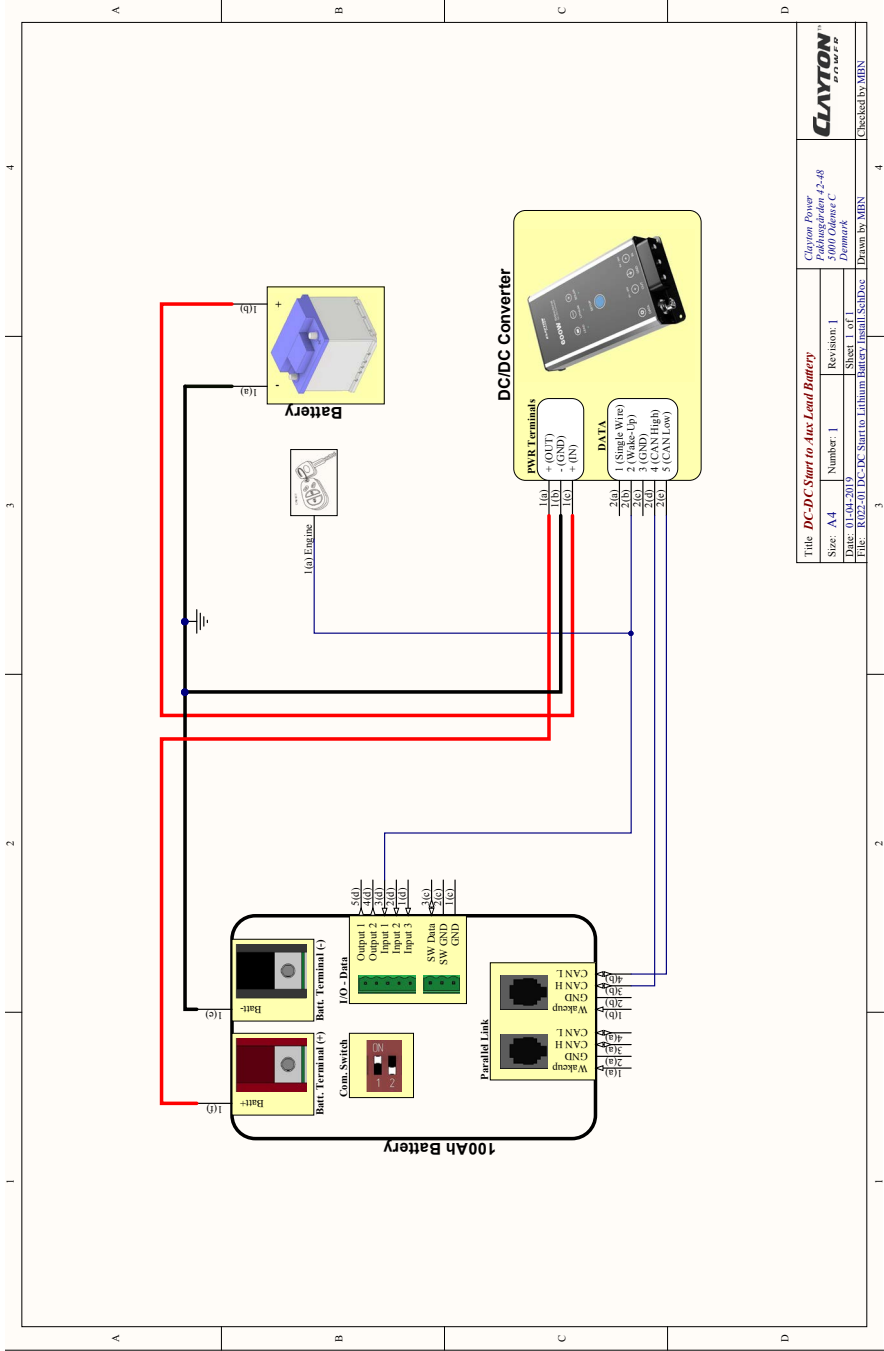

Clayton Power Produktionsdivision 42-48 50000 Odensee C D-20096 Hamburg	
Title: <b>DC-DC Start to Aux Lead Battery</b>	Revision: 1
Size: A4	Number: 1
Date: 01-04-2019	Sheet: 1 of 1
File: R02-201 DC-DC Start to Lithium Battery Test/Setup	
Drawn by: MBN	

Checked by: MBN

# Warranty

## **CAUTION & WARNING:**

**DO NOT USE OR ATTEMPT TO USE THIS PRODUCT UNTIL YOU HAVE READ THIS USER'S MANUAL IN ITS ENTIRETY. IMPROPER INSTALLATION OR USAGE OF THIS DEVICE MAY BE HAZARDOUS AND MAY CAUSE DAMAGE TO OTHER ELECTRICAL EQUIPMENT AND WILL VOID WARRANTY.**

Clayton Power warrants, to the original purchaser only, for a period of 24 months from the date of purchase, that the Clayton Power device will be in good working order when properly installed and operated as described in this manual.

If the device fails within this period of time under normal use, Clayton Power will, free of charge, at a place of Clayton Power's choosing, repair or replace the device - with new or reconditioned parts or a new or reconditioned device as Clayton Power deems necessary.

This warranty is not valid in cases of:

Usage against the recommendations of this manual.

Usage in applications outside of general automotive, solar, industrial or marine applications without the consent of Clayton Power.

Device modification or repair without written authorization from Clayton Power.

Reverse polarity, excessive overloading, general abuse, neglect, wear & tear, ingress of liquids (water, oil, acid, or otherwise), foreign objects, lightning strikes, over or under voltage, RFI/EMI, etc.

## Obtaining Warranty Service

To obtain warranty service, please contact the outlet at which you purchased your product. Do not contact Clayton Power directly. For warranty service provide the following:

- Proof of purchase
- The unit model number
- The unit serial number
- A brief description of the application and problem including any failure codes displayed on the unit.
- Contact your Clayton Power dealer for an authorization number prior to dispatch - do not send without authorization.
- Once this number has been obtained, please carefully pack your unit and send (freight paid) to the Clayton Power dealer.

## **Copyright**

The information contained within this document remains the sole property of Clayton Power. No part of this document may be copied or reproduced in any form or by any means, and the information contained within is not to be communicated to third parties, without the prior written consent of Clayton Power.